

1

Perception and Attention

1. Why should we care?
or, Why are these interesting problems?
2. Biology of the Visual System.
3. Primary Visual Representations & Hebbian Learning.
4. Object Recognition.
5. Spatial Attention.

2

Perception is Interesting!

Sure, it all seems to happen automatically, but you won't believe what is going on "under the hood.."

Interesting Problems

1. Why does primary visual cortex encode oriented bars of light?
2. Why is visual system split into what/where pathways?
3. Why does parietal damage cause attention problems (neglect)?
4. How do we recognize objects (across locations, sizes, rotations with wildly different retinal images)?

3

Overview of the Visual System

Hierarchies of specialized visual pathways, starting in retina, to LGN (thalamus), to V1 & up:

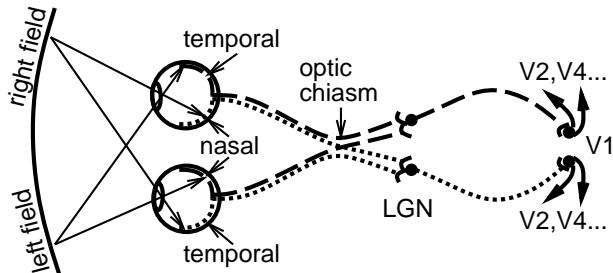

4

Two Streams: Ventral "what", Dorsal "where"

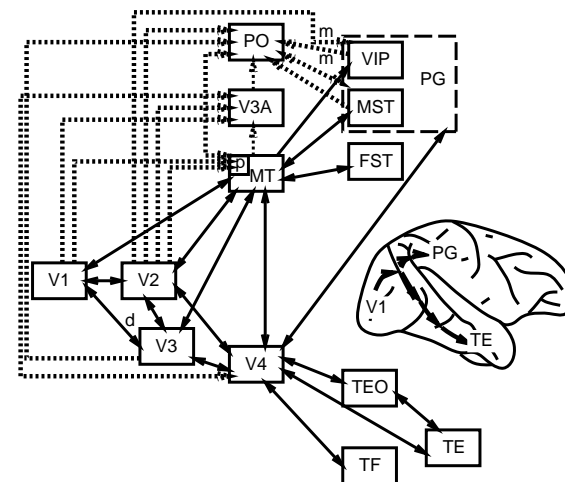

5

The Retina

Retina is *not* a passive “camera”.

Key principle: *contrast enhancement* that emphasizes *changes*.

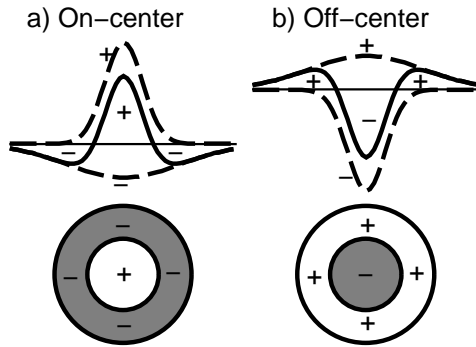

6

LGN of the Thalamus

A “relay station”, but so much more!

- Organizes different types of information into different layers.
- Performs *dynamic* processing: magnocellular motion processing cells, attentional processing.

7

Primary Visual Cortex (V1): Edge Detectors

V1 combines LGN inputs into oriented *edge detectors*:

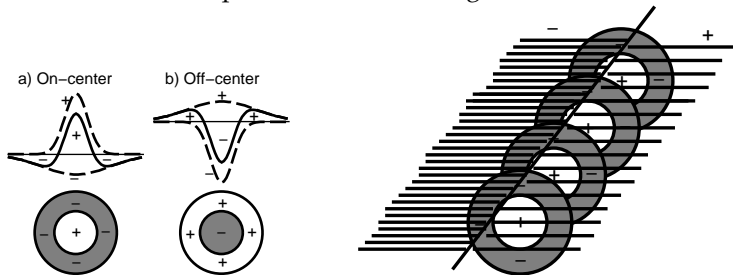

8

Primary Visual Cortex (V1): Topography

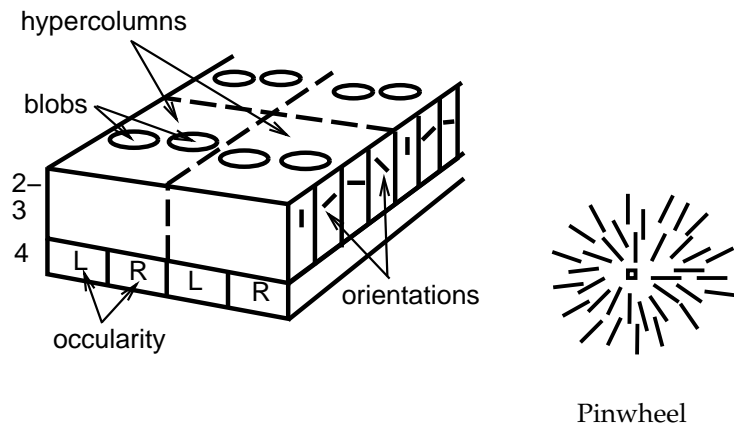

9

A question...

What makes visual cortex visual cortex? Why does it represent what it does?

10

Primary Visual Representations

Key idea: Oriented edge detectors can develop from Hebbian correlational learning based on natural visual scenes.



11

The Model

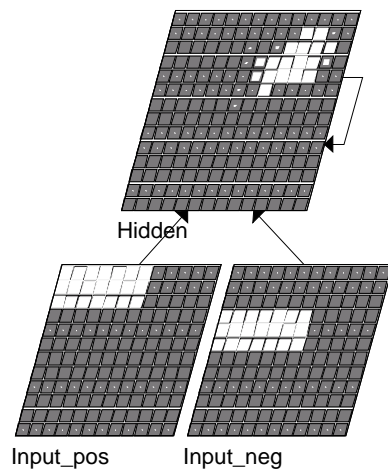

12

The Receptive Fields

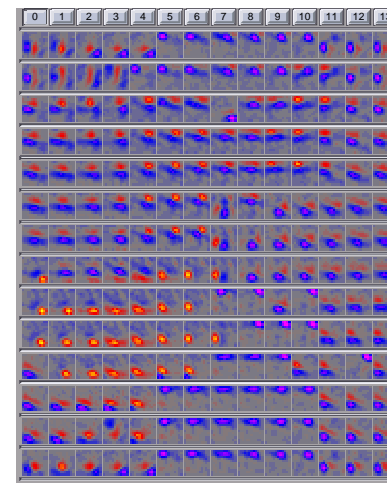

13

Perception and Attention

1. Why should we care?
or, Why are these interesting problems?
2. Biology of the Visual System.
3. Primary Visual Representations & Hebbian Learning.
4. Object Recognition.
5. Spatial Attention.

14

Object Recognition

1. The Problem & Possible Solutions.
2. Gradual Invariance Transformations.
3. Structure of the Model.

15

Problem & Possible Solutions

Problem: Recognize object regardless of: location, size, rotation.

Solution: Canonicalize to 3-D model (Marr, Hinton):

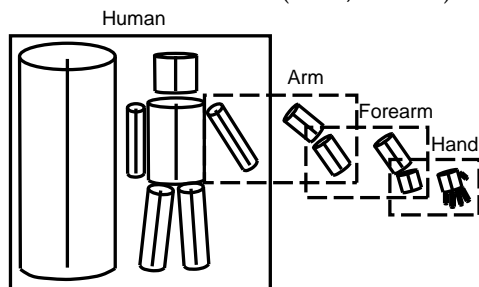

Flaw: Underconstrained! Many 2-D projections map onto many 3-D structures, and search space is huge!

16

How can a neural network solve this problem?

Example of letter recognition.

17 Alternative: Gradual Invariance Transformations

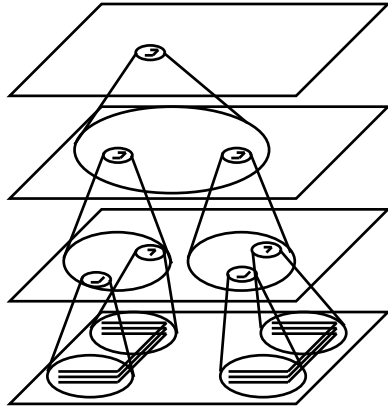

Each layer produces incremental increase in invariance and featural complexity.

18

The Model

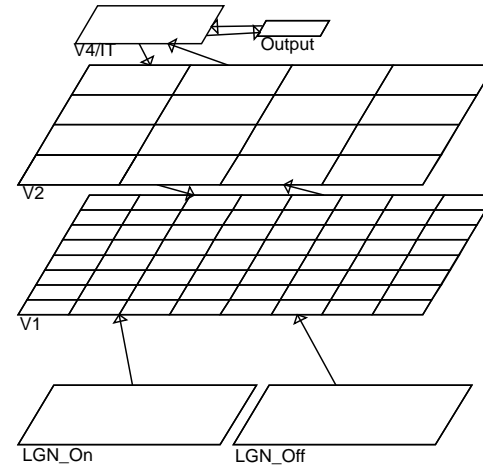

19

The Objects

